

HAZARDOUS LOCATION SERIES HL56LV

480 VOLT 3-PHASE NEMA 4/4X AIR CONDITIONERS



NEMA
TYPE 12, 3R AND
4/4X
MAINTAINED

U.S. Patent No.
9,157,670 B2

Model	NEMA Rating	BTU/H Capacity	95/95 Rating BTU/H	Ambient Temp.				Volts	Hz	* Running Amps 125°F/125°F	Pressurized Compartment Volume cu. ft.	Air Leakage @ 0.5 i.w.g. Pressure CFM	Approx. Weight Lbs. Kg.
				°F		°C							
				Max.	Min.	Max.	Min.						
K3A6C12HL56LV	4/4X	12000	11000	125	-20	52	-29	480	60	6.0	10.8	0.4	237 107

* Rating is shown for operation at maximum ambient temperature.

STANDARD FEATURES

- All models UL Listed per UL 484, Special Purpose Air Conditioners
- All models UL Recognized per NFPA 496: 2013, Purged and Pressurized Enclosures for Electrical Equipment
- Meets NEC Class I Division 1, Groups A, B, C & D and Class I, Zone 1, Groups IIA, IIB plus hydrogen and IIC Hazardous Locations when used with an approved Type X Purge System on the electrical enclosure
- Meets NEC Class I Division 2, Groups A, B, C & D and Class I, Zone 2, Groups IIA, IIB plus hydrogen and IIC Hazardous Locations when used with an approved Type Z Purge System on the electrical enclosure
- Temperature Classification is T-4, 275°F/135°C
- Maintains NEMA Type 12, 3R & 4/4X Ratings per UL 50, Cabinets and Boxes
- Closed-Loop Cooling
- Compressor Short Cycle Protector
- Filter
- Interior and Exterior Purge Connections
- Internal Corrosion Protection
- Painted Condenser and Evaporator Coils
- Pressure Compensation Terminal Block
- Programmable Temperature Alarm
- Programmable Thermostat
- Shock and Vibration Resistance
- Stainless Steel Shell
- Zero ODP Refrigerant

ACCESSORIES AND OPTIONS

- Enclosure Heater
- Filter Recoating Adhesive
- Lead-Lag Controller
- Remote Monitoring
- Remote Thermostat Relay
- Replacement Filters

PERFORMANCE

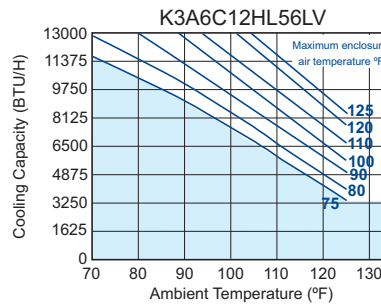

Operation within shaded area not recommended.

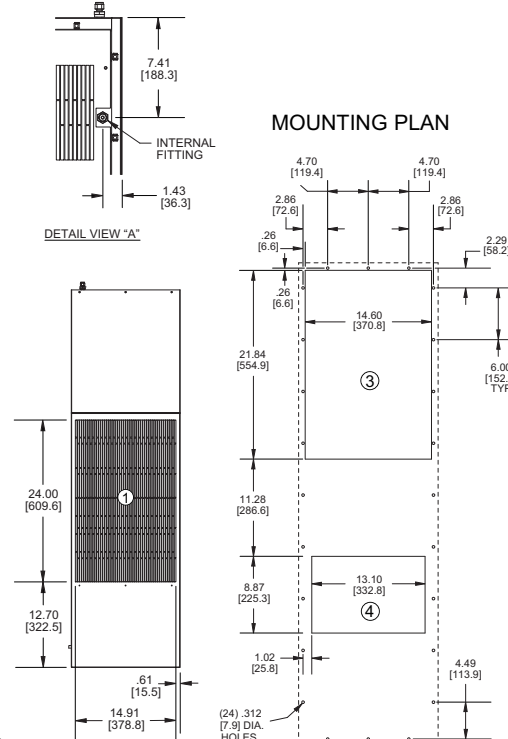
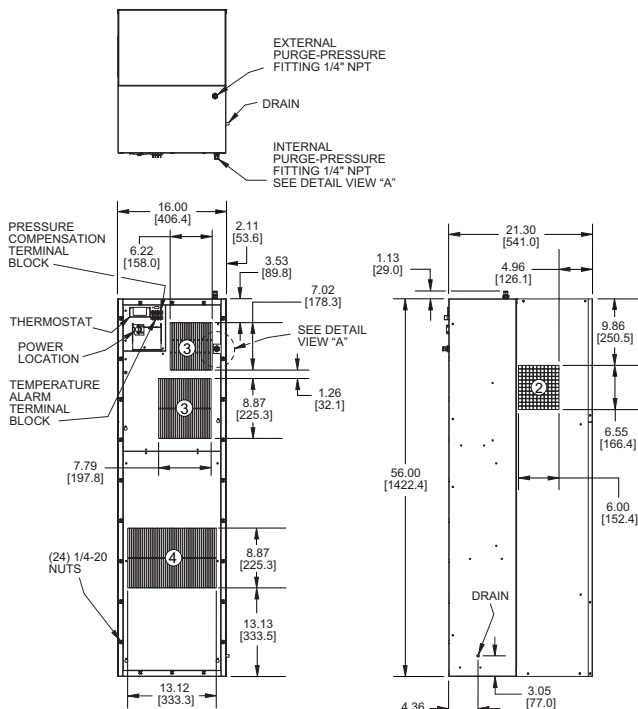
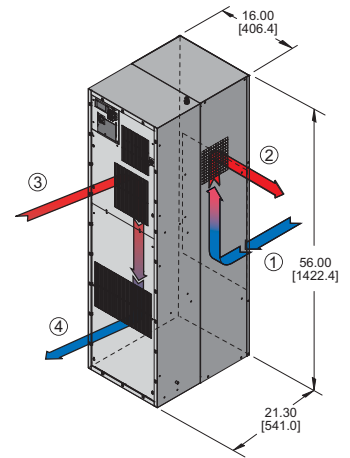

- CONDENSER AIR INLET (Ambient Air In)
- CONDENSER OUTLET (Warm Ambient Air Out)
- WARM AIR RETURN FROM ENCLOSURE
- COOL AIR OUTLET TO ENCLOSURE

Find additional information on this model at kooltronic.com, or use the Technical Documents QR code below.

Technical Documents



Many popular units are available as 3D solid models for customer system integration. Please contact Kooltronic for details.

Dimensions, inches [mm], are for reference only and are subject to change.

hl56l.qxd 8/30/17

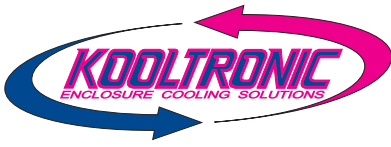

HAZARDOUS LOCATION SERIES HL56LV

480 VOLT 3-PHASE NEMA 4/4X AIR CONDITIONERS

DESCRIPTION

Robust engineering, industrial-grade construction and UL Listing are the reasons that the Kooltronic **Hazardous Location Series** Air Conditioners provide the durability and safety required by hazardous location applications.

Kooltronic **Hazardous Location Series** Air Conditioners are ideal for:

- Offshore oil rigs, onshore oil company offices and refineries
- Petrochemical sites and propane fill-up stations
- Paint and varnish storage or processing plants
- Grain alcohol processors or storage sites
- Munitions plants or armories
- PVC or plastics plants and processing plants
- Recycling plants
- Furniture refinishing/stripping workshops
- Fertilizer plants
- Hazardous materials storage



FEATURES AND BENEFITS (STANDARD)

All models UL/CUL Listed and Recognized, a standard of safety.
CFC-free refrigerant provides a zero ozone depletion potential.
Closed-loop cooling provides stable temperature control while excluding dust and humidity from the electrical enclosure.
Compressor short cycle protector extends compressor life.
Condenser filtration to maintain peak thermal performance extends compressor life.
Pressure compensation terminal block allows user to attach auxiliary pressure supply.
Programmable temperature alarm to alert if early action required.
Programmable thermostat capable of remote monitoring and control.
Interior and exterior purge connections offer versatility and convenience.
Internal corrosion protection to increase reliability in hostile environments.
NEMA 12, 3R & 4/4X ratings for compatibility with electrical enclosure ratings.
Stainless steel shell for NEMA 4X corrosive environments.
All models are designed to withstand shock and vibration in two different planes for a minimum of 4 hours per plane at 1G acceleration.
Both evaporator and condenser coils are epoxy coated, prolonging unit life.
Type X and Z purge fittings for simple connection to enclosure purge system.

FEATURES AND BENEFITS (OPTIONAL)*

Enclosure heater eliminates damaging condensation, increasing reliability of electrical enclosure components.
Lead-lag control for two air conditioners provides for capacity control, and alternates usage, increasing reliability.
Remote monitoring provides temperature data for warning of early action required.
Remote thermostat relay for control by a user-supplied control system.

Special paint finishes*

*Contact KOOLTRONIC for more information.

REPLACEMENT FILTERS

The HL56LV Filter Part No. is 1524F (15.75" 24.75" x 0.38" [400.0mm x 628.6mm x 9.7mm])