



KXNP33 TRIMLINE AIR-TO-AIR PANEL-MOUNTED HEAT EXCHANGERS

TECHNICAL DATA*

Model	Volts	Power		Maximum Temperature °F		Performance Watts/°F (Air In)	Approx. Weight (lbs.)
		Amps	Watts	Enclosure	Ambient		
KXNP33	115	2.60	227	160	-20 to 131	33	56
K2XNP33	230	1.90	227	160	-20 to 125	33	56



**NEMA
TYPE 12
MAINTAINED**



STANDARD FEATURES

- Closed-Loop Near-Ambient Cooling
- Convuluted Aluminum Element
- Filter
- Heavy-duty Steel Shell
- NEMA 12 Rating Maintained (UL50)
- Removable Element Access Panel
- UL/CUL Listed

ACCESSORIES AND OPTIONS

- Epoxy-coated element
- Filter Recoating Adhesive
- Lifting Eyes
- Low Airflow Detector
- Other voltages and frequencies
- Replacement Filters
- Special materials or finishes
- Special motors, line cords or connectors
- Stainless or Aluminum Shell
- Temperature Alarm
- Weather Protection Kit

PERFORMANCE*

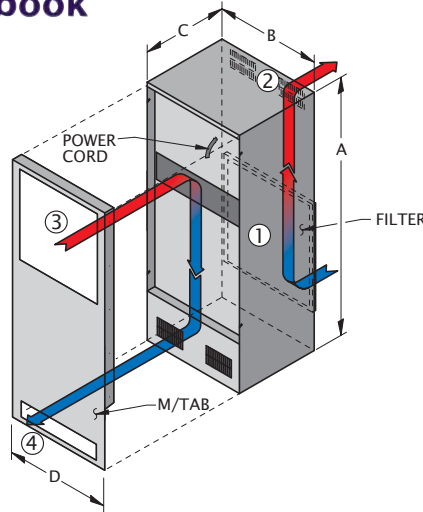
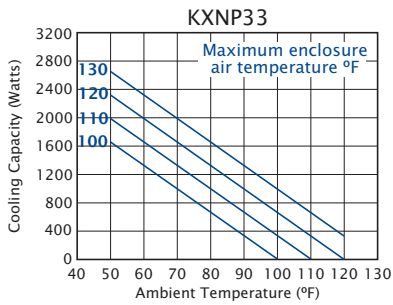

DIMENSIONS

KXNP33		
A	32.88	[835.2]
B	12.50	[317.5]
C	9.75	[247.7]
D	12.19	[309.6]
E	0.38	[9.7]
F	2.75	[69.9]
G	9.13	[231.9]
H	19.63	[498.6]
J	9.00	[228.6]
K	10.50	[266.7]
L	11.19	[284.2]
M	7.38	[187.5]
N	8.00	[203.2]
P	8	

- ① FILTERED CONDENSER AIR INLET (Ambient Air In)
- ② CONDENSER OUTLET (Warm Ambient Air Out)
- ③ WARM AIR RETURN FROM ENCLOSURE
- ④ COOL AIR OUTLET TO ENCLOSURE

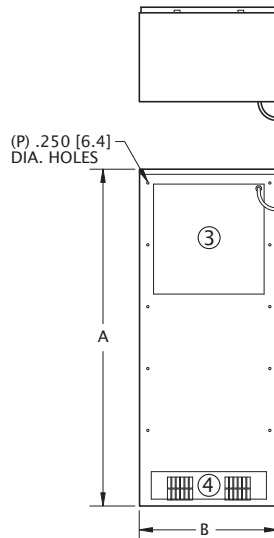
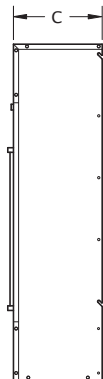
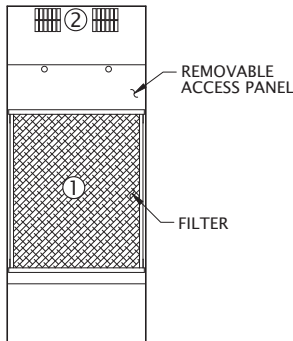

MOUNTING PLAN

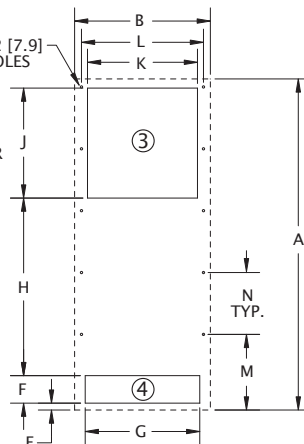

Dimensions, inches [mm], are for reference only and subject to change.

* 60 Hz. operation. For 50 Hz. operation, consult Kooltronic.

kxnp33.qxd 8/25/17

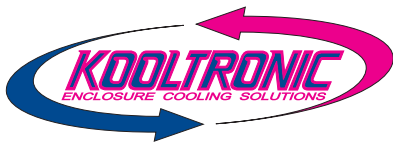

KXNP33 TRIMLINE AIR-TO-AIR PANEL-MOUNTED HEAT EXCHANGERS

DESCRIPTION

The versatile, narrow *TrimLine KXNP Heat Exchangers* feature the KOOLTRONIC exclusive refrigerant-free, convoluted, embossed aluminum heat transfer elements. These state-of-the-art elements and specially-sized KOOLTRONIC double-inlet blowers provide excellent near-ambient cooling performance in a closed-loop system.

These features provide the ultimate in cooling flexibility when designing enclosures for applications that can have varying heat loads.

Where internal temperatures must be kept below ambient, one of the *KPHE Series Water-to-Air Heat Exchangers* or either *Air-Cooled* or *Water Cooled Air Conditioners* should be considered.

Outdoor or corrosive environments require weather protection and/or special internal and external protective features. Also see *Integrity NEMA 4/4X Series*.

KOOLTRONIC also designs and manufactures a variety of Heat Exchangers to meet *unique* specifications. We invite your inquiries about our modification and custom-design capabilities.

STANDARD FEATURES

CLOSED-LOOP COOLING: The enclosure interior airflow system is isolated from the ambient airflow system. No ambient air can invade the cool, dehumidified sensitive component compartment.

PRECISION BALL-BEARING MOTORS: All blower motors are UL/CSA Recognized and include automatic-reset thermal overload protection and double-sealed or double-shielded precision ball bearings. Special permanent lubricants perform over a broad temperature range: -20°F [-28.9°C] to 250°F [121.1°C]. Consult KOOLTRONIC for motors designed to meet military or other extreme environmental specifications.

BLOWERS: All centrifugal blowers are Kooltronic-designed and built, to provide optimum airflow and pressure for each Heat Exchanger design.

RUGGED CONSTRUCTION: Precision-engineered heavy gauge steel construction of all shells and blowers insures Heat Exchangers will stand up under tough applications.

BAKED POWDER FINISH: Durable, baked-on gray powder finish is standard. Other finishes are available.

POWER: Available in 115 VAC, 60 Hz or 50/60 switchable and 230 VAC, 50 Hz or 60 Hz.

FILTERS: The filters included with all Heat Exchangers consist of a multi-layer grid of sturdy, corrugated aluminum in a one-piece aluminum frame. Filters must be kept free of accumulations, to prevent reduction or loss of performance and/or damage to equipment.

POWER CORD: All 115 and 230VAC models are supplied with six-foot three-wire cord with plug. BLDC units have three-wire cords without plugs for direct wiring to power source. Special lengths and/or plugs are available.

GASKETING: All units are fully gasketed for tight, leakproof installation, in compliance with the NEMA 12 Enclosure Rating.

UL/CUL LISTED: All *TrimLine KXNP33 Series* are *Listed*.

ACCESSORIES AND OPTIONS**

FACTORY-INSTALLED OPTIONS:

ALUMINUM SHELL: Where light weight and/or compatibility with appearance of Aluminum Enclosures are required. Unpainted Type 5052 is standard. Other types and ultra-violet-resistant baked powder finish are available.

Append letter "A" to Part No. (5052 Unpainted)

EPOXY-COATED ELEMENT: Fabricated to the same standards as the uncoated convoluted aluminum elements, these are made from epoxy-coated aluminum stock that passed 1000 hour salt spray testing.

Append letter "E" to Part No.

LIFTING EYES: A pair of heavy-gauge steel lifting eyes, attached to the side panels, assist in positioning units.

Append letter "K" to Part No.

LOW AIRFLOW DETECTOR: Similar to the Airflow Switch described as a Blower Accessory, this switch is installed in a suitable location in the heat exchanger to detect loss of airflow, and sends a signal to a terminal block, through which user-installed wiring and warning devices are activated.

Append letter "M" to Part No.

****Contact KOOLTRONIC for information.**

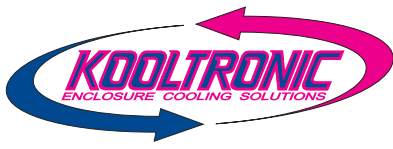

KXNP33 TRIMLINE AIR-TO-AIR PANEL-MOUNTED HEAT EXCHANGERS

ACCESSORIES AND OPTIONS** (continued)

OTHER VOLTAGES AND FREQUENCIES**

SPECIAL MATERIALS OR FINISHES**

SPECIAL MOTORS, LINE CORDS OR CONNECTORS**

STAINLESS STEEL SHELL: For applications in corrosive or other hostile environments such as those requiring Internal Corrosion Resistant Coatings, especially where chemical/moisture combinations are present.

Append letter "V" to Part No. (304-2B Unpainted)

TEMPERATURE ALARM: A thermostat is mounted inside the cabinet and attached to a sensor in the warm air return. When the air temperature increases to the set point, a signal is sent to a terminal block. User-installed wiring from the terminal block to local and/or remote warning devices (*light, bell, siren, etc.*) can be for normally open or closed operation.

Append letter "B" to Part No.

CUSTOMER-INSTALLED OPTIONS:

FILTER RECOATING ADHESIVE: This compound is a superior product for recoating filters after washing. The adhesives penetrate dirt layers to keep the filter surface tacky for longer effective performance between washings.

Part No. A-16 - 10 ounce container.

REPLACEMENT FILTERS: All KOOLTRONIC filters consist of a multi-layer grid of sturdy corrugated aluminum, securely held in a one-piece aluminum frame. Filters are required wherever air is drawn into an electronics enclosure or related cooling equipment to keep internal parts as clean as possible.

A non-drying adhesive coating traps a high percentage of particulate matter. These filters are reuseable, they may be washed and recoated with the appropriate filter recoating adhesive. Replacements are available for those which become damaged or otherwise non-serviceable.

Part No. 12251F (16.63" x 11.88" x 0.50" [422mm x 302mm x 13mm])

WEATHER PROTECTION KIT: For outdoor installations subject to invasion by rain, snow or windblown dirt, special deflectors shield the condenser air inlet and outlet ports. Air conditioners or heat exchangers installed outdoors require special exterior paint.

**Contact KOOLTRONIC for information.

HOW TO ORDER

Specify model number. NOTE: Accessories and Options may affect model number, contact KOOLTRONIC for information.

For assistance in model selection, refer to the Heat Exchanger Sizing and Selection Guide, contact KOOLTRONIC, or use one of our design aid software programs, available FREE.

**CALL 1-800-321-KOOL (5665)
or FAX 609-466-1114**

**POPULAR MODELS ARE
STOCKED AND READY TO SHIP**