

THIS DOCUMENT IS THE PROPERTY OF KOOLTRONIC, INC. AND CONTAINS PROPRIETARY AND CONFIDENTIAL INFORMATION WHICH MUST NOT BE DUPLICATED, USED OR DISCLOSED OTHER THAN AS EXPRESSLY AUTHORIZED BY KOOLTRONIC, INC.

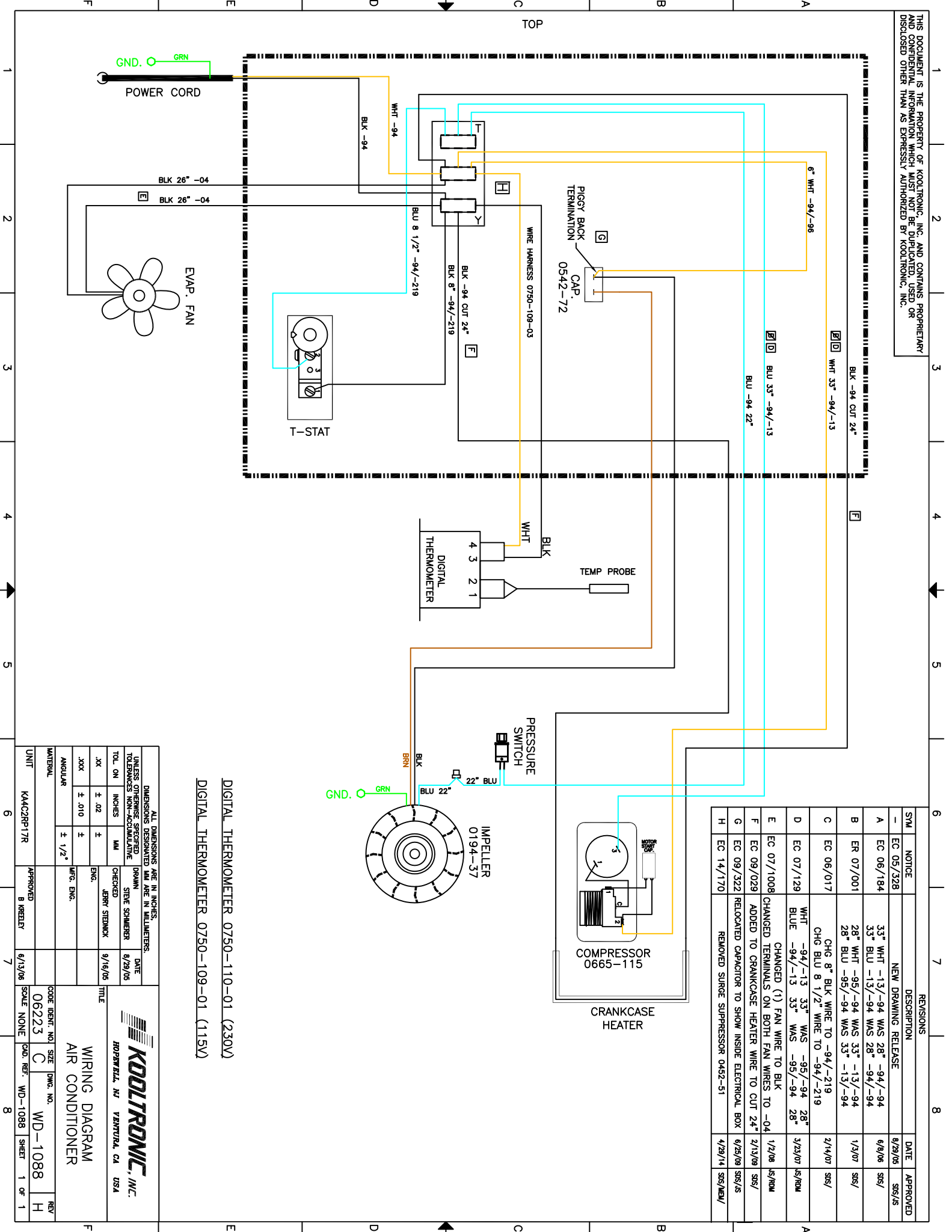

REV	NOTICE	DESCRIPTION	DATE	APPROVED
-	EC 05/328	NEW DRAWING RELEASE	8/29/06	SSS/JS
A	EC 06/184	33" WHT -13/-94 WAS 28" -94/-94 33" BLU -13/-94 WAS 28" -94/-94	6/8/08	SSS/
B	ER 07/001	28" WHT -95/-94 WAS 33" -13/-94 28" BLU -95/-94 WAS 33" -13/-94	1/3/07	SSS/
C	EC 06/017	CHG 8" BLK WIRE TO -94/-219 CHG BLU 8 1/2" WIRE TO -94/-219	2/14/07	SSS/
D	EC 07/129	WHT -94/-13 33" WAS -95/-94 28" BLU -94/-13 33" WAS -95/-94 28"	3/23/07	SSS/SSM
E	EC 07/1008	CHANGED (1) FAN WIRE TO BLK CHANGED TERMINALS ON BOTH FAN WIRES TO -04	1/2/08	SSS/SSM
F	EC 08/029	ADDED TO CRANKCASE HEATER WIRE TO CUT 24"	2/13/08	SSS/
G	EC 09/322	RELOCATED CAPACITOR TO SHOW INSIDE ELECTRICAL BOX	6/25/08	SSS/JS
H	EC 14/170	REMOVED SURGE SUPPRESSOR 0452-51	4/29/14	SSS/MSU/

DIGITAL THERMOMETER 0750-110-01 (230V)
 DIGITAL THERMOMETER 0750-109-01 (115V)

ALL DIMENSIONS ARE IN INCHES. DIMENSIONS DESIGNATED MM ARE IN MILLIMETERS. UNLESS OTHERWISE SPECIFIED TOLERANCES NON-ACCUMULATIVE		DRAWN STEVE SCHUBERT 8/29/06	DATE 8/29/06
TOL. ON	INCHES	CHECKED	DATE
.XX	± .02	JERRY STEWICK	9/16/06
.XXX	± .010	ENG.	
ANGULAR	± 1/2°	MFG. ENG.	
MATERIAL			
UNIT	KA4C2RP17R	APPROVED	
		B KREBELY	6/13/08
CODE IDENT. NO. SIZE DWG. NO. 06223 C WD-1088		TITLE KOOLTRONIC, INC. HOPWELL, NJ VENTURA, CA USA WIRING DIAGRAM AIR CONDITIONER	
SCALE	NONE	SHEET	1 OF 1